



Semester One Examination, 2021

Question/Answer booklet

MATHEMATICS METHODS UNIT 1

Section One: Calculator-free

If required by your examination administrator, please place your student identification label in this box

WA student number: In figures

--	--	--	--	--	--	--	--

In words

Time allowed for this section

Reading time before commencing work: five minutes
Working time: fifty minutes

Number of additional
answer booklets used
(if applicable):

--

Materials required/recommended for this section

To be provided by the supervisor

This Question/Answer booklet
Formula sheet

To be provided by the candidate

Standard items: pens (blue/black preferred), pencils (including coloured), sharpener, correction fluid/tape, eraser, ruler, highlighters

Special items: nil

Important note to candidates

No other items may be taken into the examination room. It is **your** responsibility to ensure that you do not have any unauthorised material. If you have any unauthorised material with you, hand it to the supervisor **before** reading any further.

Structure of this paper

Section	Number of questions available	Number of questions to be answered	Working time (minutes)	Marks available	Percentage of examination
Section One: Calculator-free	8	8	50	52	35
Section Two: Calculator-assumed	13	13	100	98	65
Total					100

Instructions to candidates

- The rules for the conduct of examinations are detailed in the school handbook. Sitting this examination implies that you agree to abide by these rules.
- Write your answers in this Question/Answer booklet preferably using a blue/black pen. Do not use erasable or gel pens.
- You must be careful to confine your answers to the specific question asked and to follow any instructions that are specific to a particular question.
- Show all your working clearly. Your working should be in sufficient detail to allow your answers to be checked readily and for marks to be awarded for reasoning. Incorrect answers given without supporting reasoning cannot be allocated any marks. For any question or part question worth more than two marks, valid working or justification is required to receive full marks. If you repeat any question, ensure that you cancel the answer you do not wish to have marked.
- It is recommended that you do not use pencil, except in diagrams.
- Supplementary pages for planning/continuing your answers to questions are provided at the end of this Question/Answer booklet. If you use these pages to continue an answer, indicate at the original answer where the answer is continued, i.e. give the page number.
- The Formula sheet is not to be handed in with your Question/Answer booklet.

Markers use only		
Question	Maximum	Mark
1	6	
2	7	
3	6	
4	7	
5	6	
6	7	
7	6	
8	7	
S1 Total	52	
S1 Wt ($\times 0.6731$)	35%	
S2 Wt	65%	
Total	100%	

Section One: Calculator-free**35% (52 Marks)**

This section has **eight** questions. Answer **all** questions. Write your answers in the spaces provided.

Working time: 50 minutes.

Question 1**(6 marks)**

Solve the following equations for x .

(a) $(2x + 5)(x - 4) = 0$.

(2 marks)

(b) $x^2 - 10x - 11 = 0$.

(2 marks)

(c) $(x - 8)^2 - 100 = 0$.

(2 marks)

DO NOT WRITE IN THIS AREA AS IT WILL BE CUT OFF

Question 2**(7 marks)**

The straight line L has equation $4x + 2y = 1$.

- (a) Write the equation of L in the form $y = mx + c$ to show that its gradient is -2 . (1 mark)

Line L_1 is perpendicular to L and passes through the point $(2, 6)$.

Line L_2 is parallel to L and passes through the point $(1, -7)$.

- (b) Determine the point of intersection of L_1 and L_2 . (6 marks)

Question 3

(a) The graph of $y = a \sin(x + b)$ is shown below, where a and b are constants.

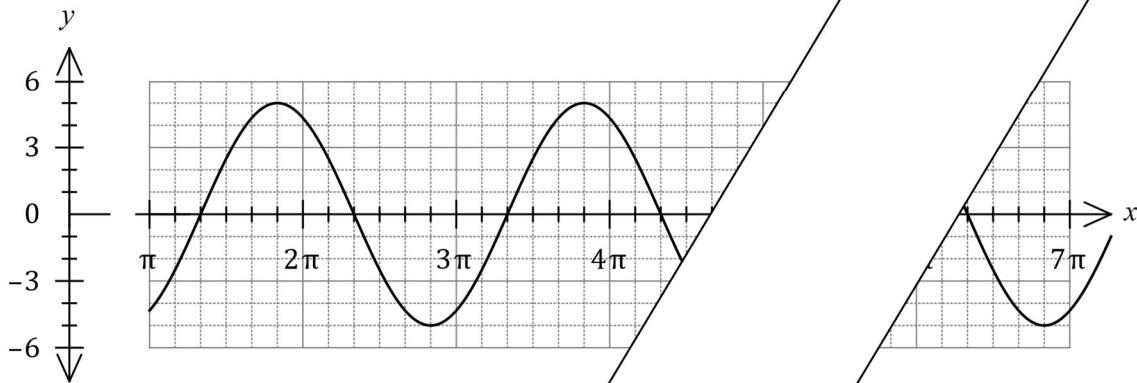

Determine the value of a and the least value of y .

(2 marks)

(b) Let $f(x) = 4 \tan\left(x - \frac{\pi}{6}\right)$.

Determine the zeros of $f(x)$ for $0 \leq x \leq 2\pi$.

(2 marks)

(c) Let $g(x) = \cos\left(x - \frac{\pi}{4}\right)$.

Determine the coordinates of the minimum of the graph of $y = g(x)$ for $0 \leq x \leq 4\pi$.

(2 marks)

DO NOT WRITE IN THIS AREA AS IT WILL BE CUT OFF

Not Assessed

Question 4

(7 marks)

Consider the function $f(x) = \frac{p}{x+q}$, where p and q are constants. The graph of $y = f(x)$ has an asymptote with equation $x = 2$ and passes through the point $(6, -1)$.

(a) Determine the value of p and the value of q . (3 marks)

(b) State the equation of the other asymptote of the graph of $y = f(x)$. (1 mark)

(c) Sketch the graph of $y = f(x)$ on the axes below. (3 marks)

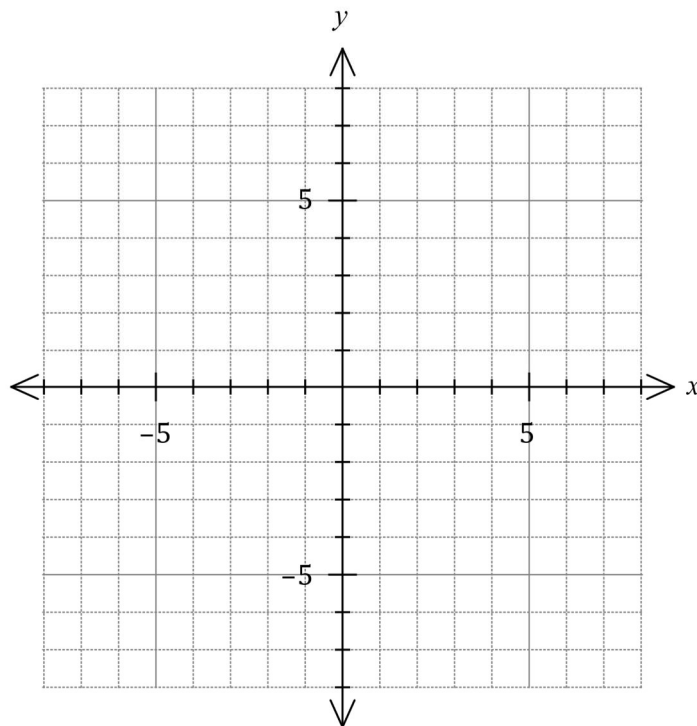

Question 5

(a) A unit circle is shown.

Mark on the circumference of the circle the points P and Q so that rays drawn from the origin to each point make clockwise angles of 285° and $\frac{7\pi}{12}$ from the positive x -axis respectively.

Hence estimate the value of $\sin 285^\circ$ and the value of $\cos\left(\frac{7\pi}{12}\right)$.

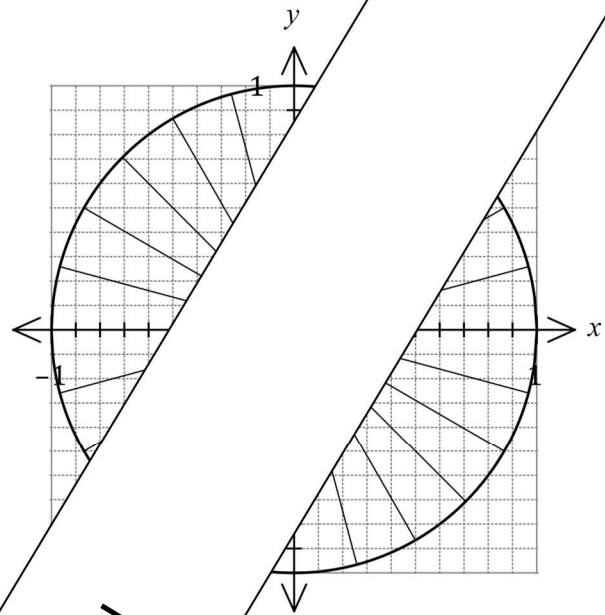

(3 marks)

Not Assessed

(b) Solve the equation $\sin x = \cos x$ for $0^\circ \leq x \leq 90^\circ$.

(3 marks)

DO NOT WRITE IN THIS AREA AS IT WILL BE CUT OFF

Question 6**(7 marks)**

- (a) Determine the number of possible combinations when three students must be chosen from a small class of six. **(2 marks)**

- (b) Determine the coefficient of the x^3 term in the expansion of

(i) $(2x + 3)^3$. **(2 marks)**

(ii) $(3x - 10)^6$. **(3 marks)**

DO NOT WRITE IN THIS AREA AS IT WILL BE CUT OFF

Question 7**(6 marks)**

Two polynomial functions are defined by $f(x) = (2x - 3)(x + 2)$ and $g(x) = x^3 + 4x^2 - 4x - 12$.

Determine the coordinates of the point(s) of intersection of $f(x)$ and $g(x)$.

DO NOT COPY

DO NOT WRITE IN THIS AREA AS IT WILL BE CUT OFF

METHODS UNIT 1

10

CA

FREE

Question 8

Consider rectangle $ORST$ that contains the right triangle OPQ as shown.

Let the length of $OP = 1$,
 $\angle QOT = \angle SQP = \alpha$,
 $\angle POQ = \beta$ and
 $\angle OPR = \alpha + \beta$.

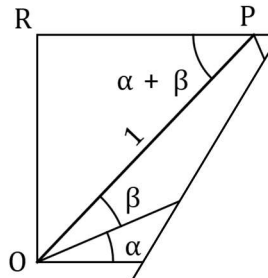

(marks)

(a) Explain why $QT = \sin \alpha \cos \beta$.

(2 marks)

(b) Determine expressions for the lengths OT and ST and hence prove the angle sum identity $\sin(\alpha + \beta) = \sin \alpha \cos \beta + \cos \alpha \sin \beta$.

and hence prove the angle sum

(3 marks)

Not Assessed

(c) Use the result from part (b) to show that $\sin\left(x + \frac{3\pi}{2}\right) = -\cos x$.

(2 marks)

DO NOT WRITE IN THIS AREA AS IT WILL BE CUT OFF

Supplementary page

Question number: _____

DO NOT WRITE IN THIS AREA AS IT WILL BE CUT OFF

